



Digital Output Pressure Sensors WF183DE

Main Features

- ◆ Digital pressure temperature direct reading
- ◆ **Operating voltage:** 2.4V~5.5V
- ◆ **Pressure range:** 0~1500kPa (absolute pressure)
- ◆ Internal complementary algorithm
- ◆ Factory calibration free
- ◆ High accuracy
- ◆ **Operating current:** 1.5mA
- ◆ **Standby power consumption:** 2uA
- ◆ **Operating temperature:** -40~+125 ° C
- ◆ **Communication interface:** IIC, UART, OWI three choose one
- ◆ **Size:** 3.8X3.6X0.8mm



Application range

- ◆ Handheld Tire Pressure Gauge, TPMS
- ◆ Weather forecasting
- ◆ Industrial pressure and temperature sensor systems
- ◆ Sports watches
- ◆ Electronic cigarettes

Product Description

The WF183DE is an economical digital pressure-temperature sensor that includes a MEMS pressure sensor and a high-resolution 24-bit ADC and DSP. The WF183DE provides high-precision digital outputs of calibrated pressure and temperature through a variety of communication interfaces. The WF183DE is factory calibrated for pressure and temperature, so it can be plug-and-play, eliminating the need for customer calibration.

A variety of communication interfaces can be selected to facilitate MCU selection and reduce the cost of the whole machine.

WF183DE is waterproof up to IP65, which meets the requirements of most waterproof products.

1. Block image

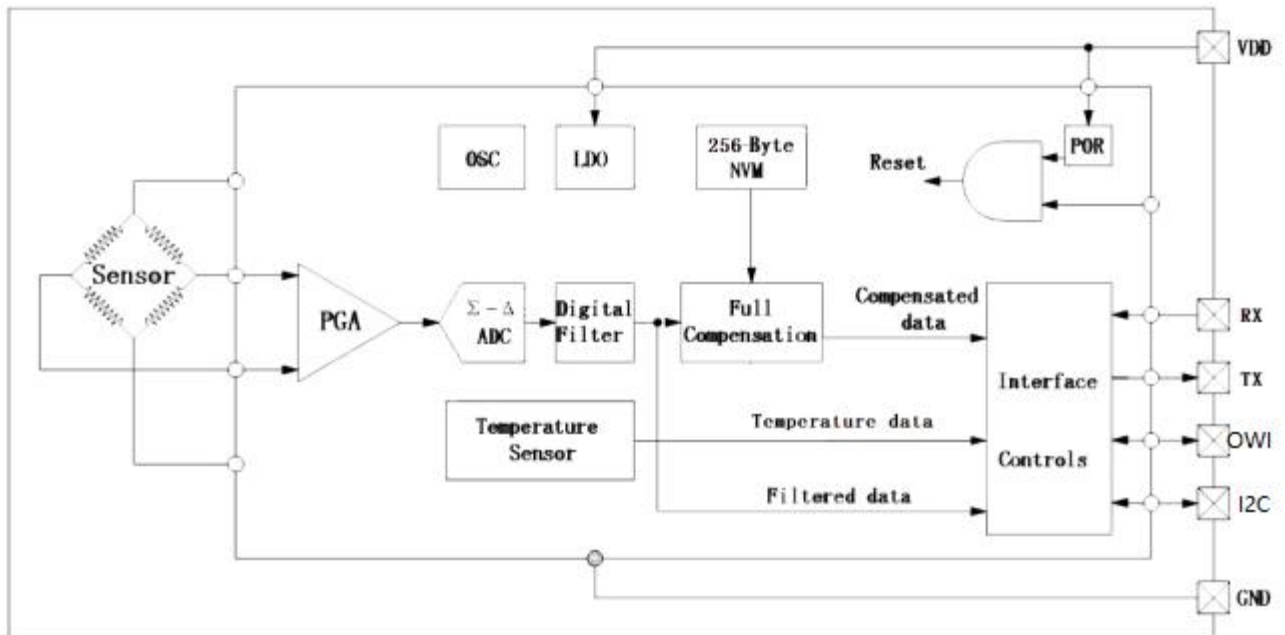

Fig. 1: Internal Block image

2. Pin Configuration

pin	name	direction	Function
1	SCL	Input	IIC Clock Input
2	GND	Input	Power supply ground
3	VDD	Input	Power supply positive
4	VS	Output	External capacitor (required)
5	RX	Input	Serial port data input
6	TX	Output	Serial port data output
7	OWI	Input/Output	Single line communication
8	SDA	Input/Output	IIC Data Port

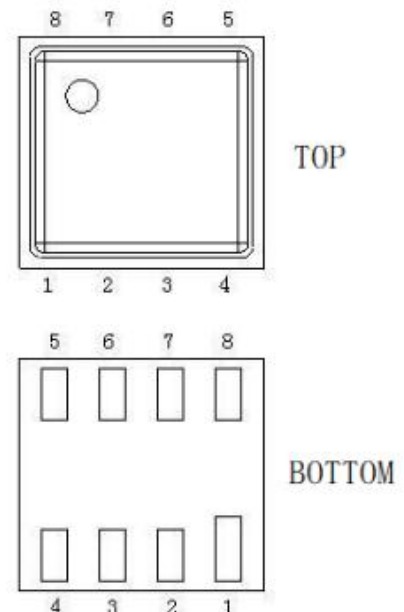

Fig. 2: Pin image



3. Electrical Characteristics

3.1 Limit parameters

Parameter	Symbol	Status	Min	Max	Unit
Overvoltage	P_{MAX}			2X	2X
Supply Voltage	V_{DD}		-0.2	5.5	V
Interface Voltage	V_{IF}		-0.3	$V_{DD}+0.3$	V
Operation Range Temperature	T_{OP}		-40	125	°C
Storage temperature range	T_{STG}		-50	150	°C
Max. welding temperature	T_{MS}	Up to 40 seconds.		250	°C

3.2 Electrical parameters

Parameter	Symbol	Environmental Conditions	Min	Standard	Max	Unit
peak current	I_{PEAK}	During the conversion process		1.5		mA
Quiescent current	I_{STB}			2	3.5	uA
Serial communications baud rate				9600		Hz
Digital Input High Voltage	V_{IH}		0.8			V
Digital Input Low Voltage	V_{IL}				0.2	V
Digital output high voltage	V_{OH}	$I_o = 0.5\text{ mA}$	0.9			V
Digital output low voltage	V_{OL}	$I_o = 0.5\text{ mA}$			0.1	V
IIC clock	F_{scl}				400	kHz

3.3 Pressure temperature parameters

Parameter	Symbol	Environmental Conditions	Min	Standard	Max	Unit
Pressure measuring range	P_{FS}		0		1500	kPa
Absolute pressure accuracy		10°C to 80°C standard atmospheric pressure		1.5		kPa
		-20°C to 125°C standard atmospheric pressure		3.5		kPa
Relative pressure accuracy		At 25°C From 0°C to 70°C		0.5		kPa
				1.5		kPa
Maximum error (voltage effect)		Voltage 2.4V to 5.5V			2.5	kPa
Pressure/height resolution		pressure mode		0.01		kPa
Drift over reflow soldering		After reflow soldering		0.5		kPa
long term drift		After 1 year		1.5		kPa
Reflow Profile		IPC/JEDEC J-STD-020C		0.5		kPa



4.UART communication mode

Serial Port Configuration

baud rate	Start bit	data bit	stop bit	Check bit
9600	1	8	1	NO

Serial Command Format

Start flag	data length	Control Instruction	Check bit
0x55	1byte	1byte	1byte

Serial Port Control Instruction set

Control Instruction	Command Word	Command string	Command function	Note
CMD_CAL_T	0x0E	55 04 0E 6A	Get real-time temperature	Calculate the current temperature once and return, always read the temperature before reading the barometric pressure.
CMD_CAL_T1	0x27	55 04 27 D5	Getting Highly Accurate Temperatures	Calculate high precision temperature and return, suitable for temperature fluctuation measurement.
CMD_CAL_P1	0x0D	55 04 0D 88	Get real-time barometric pressure	Calculate the current air pressure once and return
CMD_CAL_P2	0x26	55 04 26 8B	Getting Highly Accurate Air Pressure	Calculates and returns high-precision air pressure, suitable for measurements where air pressure fluctuates.
CMD_CAL_P3	0x3C	55 04 3C 68	Obtaining Forecast Air Pressure	Calculates predicted air pressure and returns it, suitable for measurements where air pressure fluctuates
CMD_CAL_PT4	0x41	55 06 41 03 64 85	Synchronously obtain temperature air pressure	Weifengheng patent (2020SR0930998)

Serial port return value format

Start flag	Data length	Data type	Return data	Check bit
0xAA	1 byte	1 byte	n byte	1byte

Serial port return value data type

value return data type	Type word	Back content	Return content format
RET_T	0x0A	Temperature value	S16
RET_P1	0x09	Air pressure value	U32
RET_P2	0x18	Air pressure value	U32
RET_P3	0x3C	Air pressure value	U32

Check bit description

CRC Format : CRC-8/MAXIMx8+x5+x4+1

Routine:

```

u8 Cal_uart_buf_CRC(u8 *arr, u8 len)
{
    u8 crc=0;
    u8 i=0;
    while(len--)
    {
        crc ^= *arr++;
        for(i = 0;i < 8;i++)
        {
            if(crc & 0x01) crc = (crc >> 1) ^ 0x8c;
            else crc >>= 1;
        }
    }
    return crc;
}

```

Automatically converts the pressure value after real-time temperature compensation, focus used in inflatable pump industry. The returned air pressure value is very close to the real air pressure of inflation, which can simplify the main control software algorithm and improve the accuracy of dynamic air pressure measurement. Older versions do not support this directive

Other instructions

The operation process of converting the current pressure: first acquire the temperature, then acquire the pressure. Since the conversion pressure needs to be tasted according to the current temperature, it is necessary to collect the conversion temperature first. The current temperature is converted by sending the temperature.

In normal mode: the serial port receives no signal for about 3S and then automatically enters standby.

Examples

1. Get real-time temperature value (CMD_CAL_T)

TX:55040E6A.
 RX:AA060A020122 return result (s16) 0x0102=258 258/10=25.8°C

2. Get real-time pressure value (CMD_CAL_P1)

TX : 55040D88
 RX: AA0809A08601007F Return result (u32): 0x0186A0=100000100000/1000=100kPa

UART Application Circuit

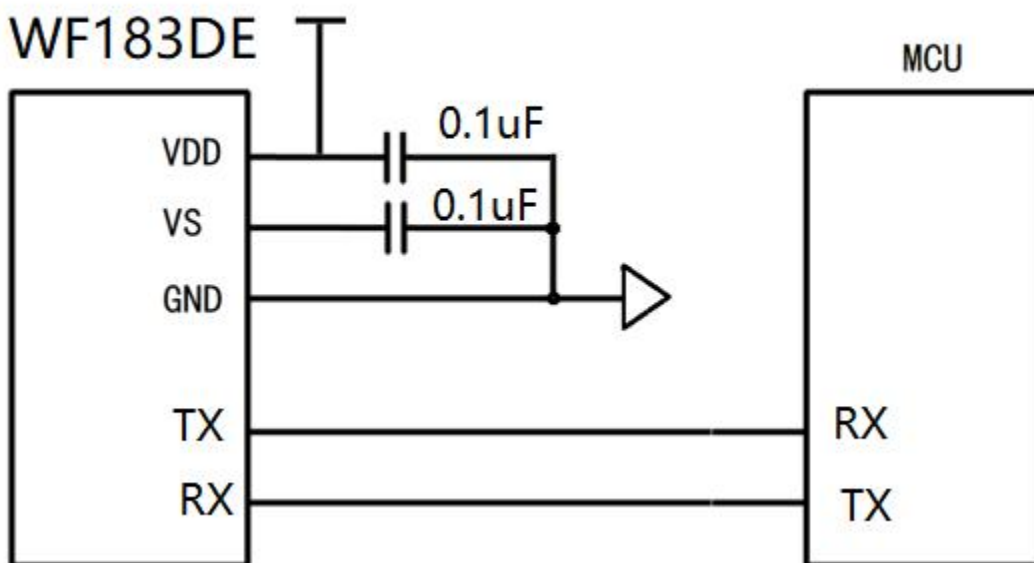

5. OWI communication mode

When the sensor is in standby, the single bus is in the input state (internal pull-up), the MCU pulls down 0.2mS, and then enters the input state to wait for the sensor to send the pressure data, and then returns to the input state after the sensor data sending is completed.

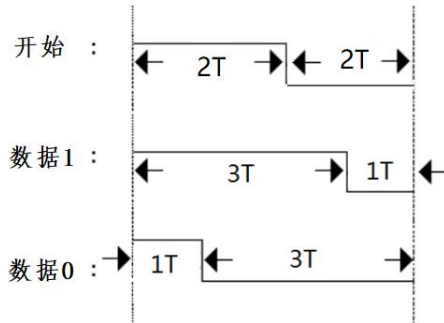

Start flag	High pressure byte	Parity bit	Start flag	Low air pressure bytes	Parity bit	Start flag	Check bytes	Parity bit
Start	1 byte	1 bit	Start	1 byte	1 bit	Start	1 byte	1 bit
Start	Pressure <15:8>	Even = 0 Odd = 1	Start	Pressure <7:0>	Even = 0 Odd = 1	Start	Pressure <15:8>+ pressure <7:0> 8-bit lower data	偶数=0 奇数=1

Example:

High byte <15:8>:0x01

low byte <7:0>:0x2C

Check bytes : 0x2D

Air pressure: 0x12C = 300KPA

OWI application circuit

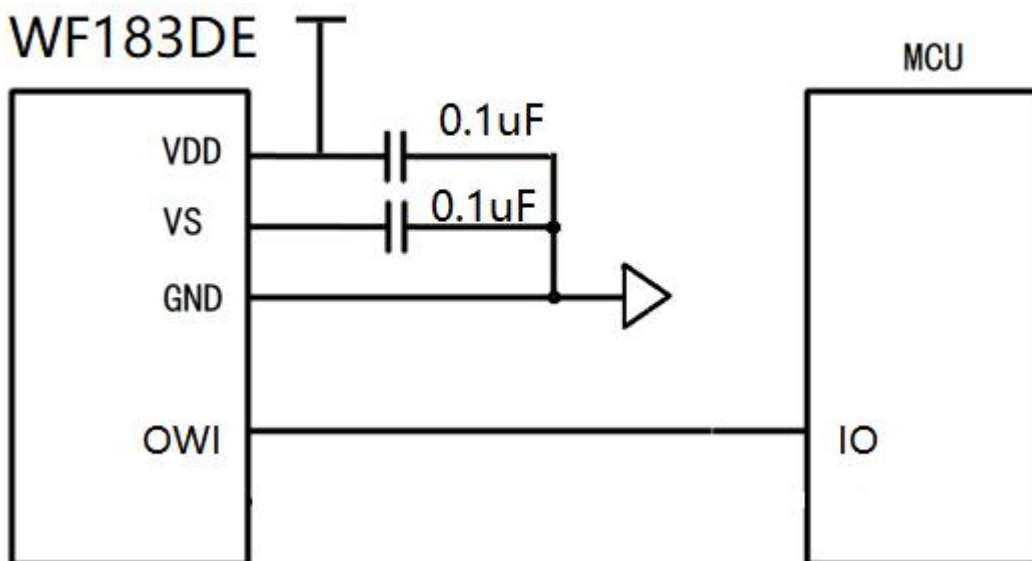



6.IIC communication mode

Slave device address: 0xDA

A7	A6	A5	A4	A3	A2	A1	Read/Write
1	1	0	1	1	0	1	0/1

Register

Add	descriptive	Read/Write	A7	A6	A5	A4	A3	A2	A1	A0	Default value	
0x0A	Command	Write	0000				0110 (Pressure) /0100 (Temperature)				0x00	
0x0B	High pressure	Read	Pressure value<31:24>									0x00
0x0C	High pressure	Read	Pressure value<23:16>									0x00
0x0D	Low pressure	Read	Pressure value<15:8>									0x00
0x0E	Low pressure	Read	Pressure value<7:0>									0x00
0x0F	High temperature	Read	Temperature value<15:8>									0x00
0x10	Low temperature	Read	Temperature value<7:0>									0x00
0x13	Status	Read	Reserved						1 Completed		0x00	

Time series

Write command	Start	Slave device address	0	responsive	Register Address	responsive	Command	responsive	Stop
Pressure	start	0xDA		Ack	0x0A	Ack	0x06	Ack	stop
Temperature	start	0xDA		Ack	0x0A	Ack	0x04	Ack	stop

Check status	Start	Slave device address	0	responsive	Register Address	responsive	Start	Slave device address	1	responsive	Read Data	No responsive	Stop
	start	0xDA		Ack	0x13	Ack	start	0xDB		Ack	<7:0>	Nack	stop

Read Data	Start	Slave device address	0	responsive	register	responsive	Start	Slave device address	1	responsive	Read Data	responsive	Read Data	responsive	Read Data	responsive	Read Data	No responsive	stop
Temperature	start	0xDA		Ack	0x0F	Ack	start	0xDB		Ack	<15:8>	Ack	<7:0>					Nack	stop
Pressure	start	0xDA		Ack	0x0B	Ack	start	0xDB		Ack	<31:24>	Ack	<23:16>	Ack	<15:8>	Ack	<7:0>	Nack	stop

Examples of data conversion

Temperature: 0x0F= 0x01 ,0x10=0x02 ;
 0x0102=258; 258/10= 25.8 ° C

Pressure: 0x0B= 0x00 ,0x0C=0x1,0x0D=0x86,0x0E=0xA0 ;
 0x186A0=100000; 100000/1000= 100 kPa

Note: The temperature must be measured once before measuring the pressure.

IIC Application circuit

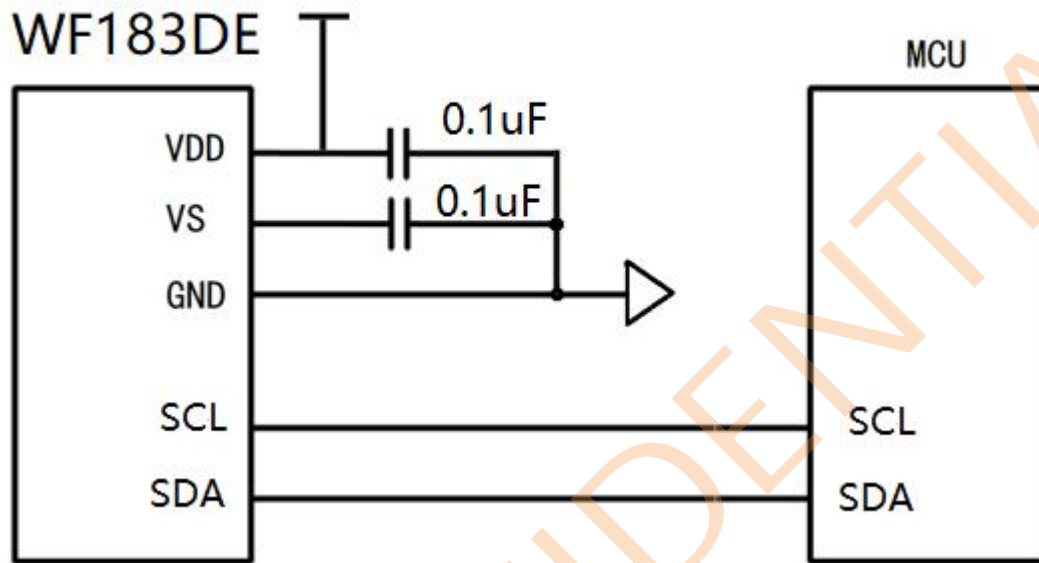



7. Package (QFN8)

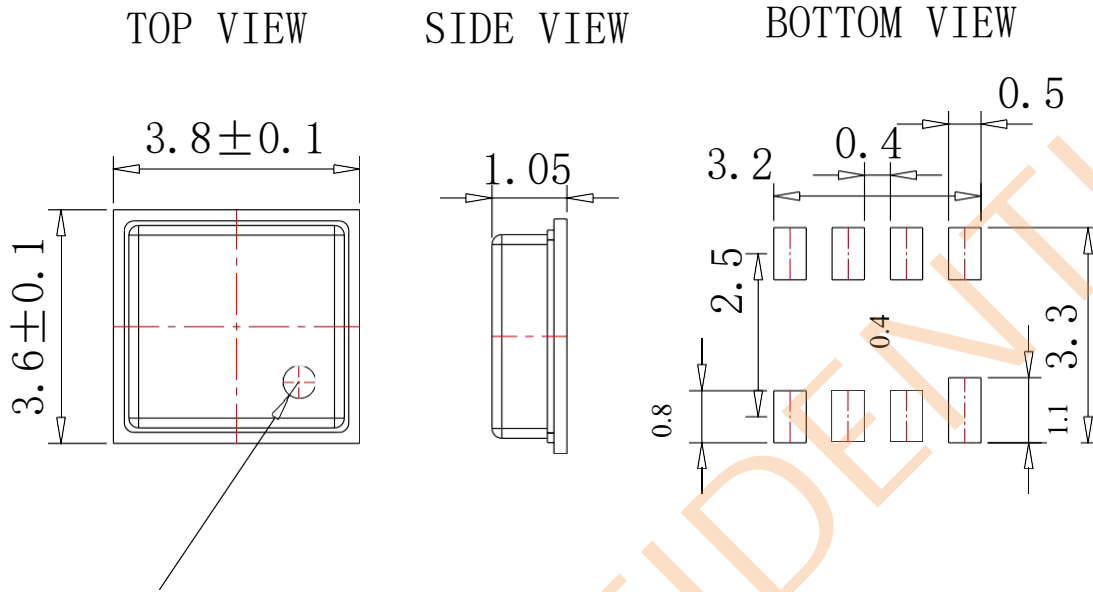

8. Package Instructions

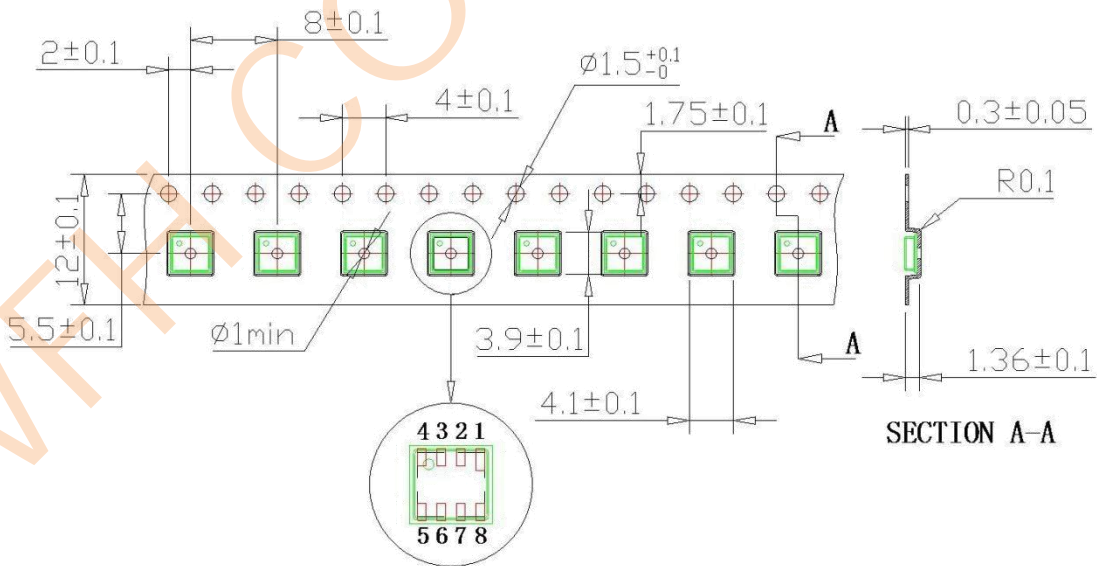

9. Reflow soldering suggestions

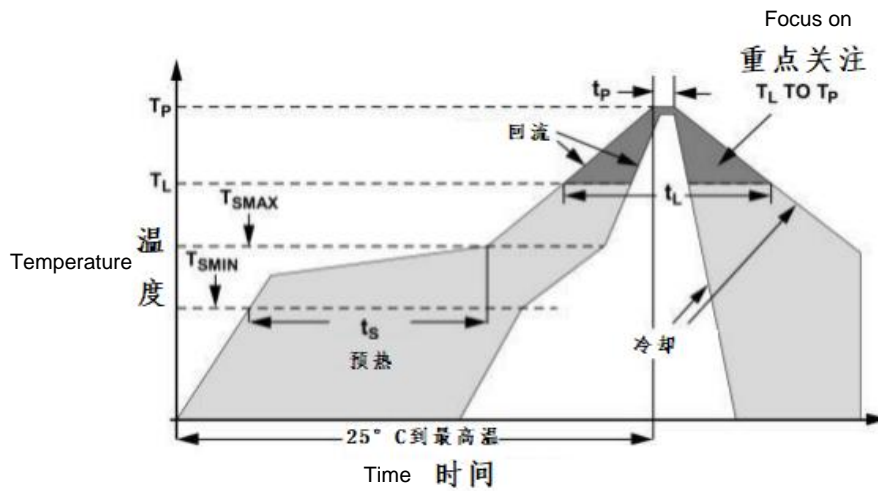

Phase	Guide value (lead-free)
Heating rate T_{SMAX} 至 T_P	Less than or equal to 3° C/s
Preheat the lowest temperature T_{SMIN}	150° C
Highest preheating temperature T_{SMAX}	200° C
Preheating time t_s (T_{SMIN} 至 T_{SMAX})	60 to 180 seconds
Minimum reflux temperature T_L	217° C
Reflux time t_L	60 to 150 seconds
Maximum reflux temperature T_P	260° C
Maximum temperature time t_p	20 to 40 seconds
Cooling rate	Less than or equal to 4° C/sec
25° C to the highest temperature	Up to 8 minutes.